

Genetics¹

by Drs. Scott Poethig, Ingrid Waldron, and Jennifer Doherty, Department of Biology, University of Pennsylvania, Copyright, 2011

We all know that children tend to resemble their parents in appearance. Parents and children generally have similar eye color, hair texture, height and other characteristics because children inherit **genes** that control specific characteristics from their parents.

Where are genes found in our bodies?

Researchers have shown that genes are parts of DNA molecules, and DNA molecules are contained in chromosomes in the nucleus of each cell in our body.

How do genes influence our characteristics?

Each gene is a segment of the DNA molecule that gives the instructions for making a protein. For example, one gene gives the instructions for making a protein enzyme which helps to make melanin, the pigment which contributes to the color of skin, eyes and hair. Different versions of the gene (called **alleles**) code for different versions of the protein. One allele of this gene codes for an enzyme that produces melanin, resulting in normally pigmented skin and hair; it is symbolized by **A**. Another allele of this gene (symbolized by **a**) codes for an enzyme that cannot produce melanin; this results in very pale skin and hair, which is called albinism.



How does a baby inherit genes from his or her mother and father?

When we talk about genes being inherited from one generation to the next, we are really talking about how the gene-carrying chromosomes behave during meiosis and fertilization. As you will see in the next section, if you understand how the mother's and father's chromosomes behave during meiosis and fertilization, you can understand why the zygote that becomes a baby has two copies of each gene, one copy from the mother and one copy from the father. In the next section, you will demonstrate this, using model chromosomes.

Inheritance of Albinism

To learn more about how genetic traits are inherited, you will analyze a specific question: If each parent has one **A** allele and one **a** allele (i.e. both parents are **Aa**), what different combinations of **A** and/or **a** alleles would you expect to observe in the children of these parents?

To answer this question your group will use four model chromosomes. The pair of homologous chromosomes for each parent will include one model chromosome with an **A** allele and a second model chromosome with an **a** allele.

¹ Teachers are encouraged to copy this student handout for classroom use. A Word file (which can be used to prepare a modified version if desired), Teacher Preparation Notes, comments, and the complete list of our hands-on activities are available at http://serendip.brynmawr.edu/sci_edu/waldron/. An alternative version of this activity that does not use model chromosomes is available in the Teacher Preparation Notes for this activity. Additional genetics activities are available at <http://serendip.brynmawr.edu/exchange/bioactivities>.

1. One of you should be the mother and use your model chromosomes to demonstrate how meiosis produces different types of eggs, and another should be the father and demonstrate how meiosis produces different types of sperm. In the chart below, write in the genetic makeup of the two types of eggs and the two types of sperm produced by meiosis.

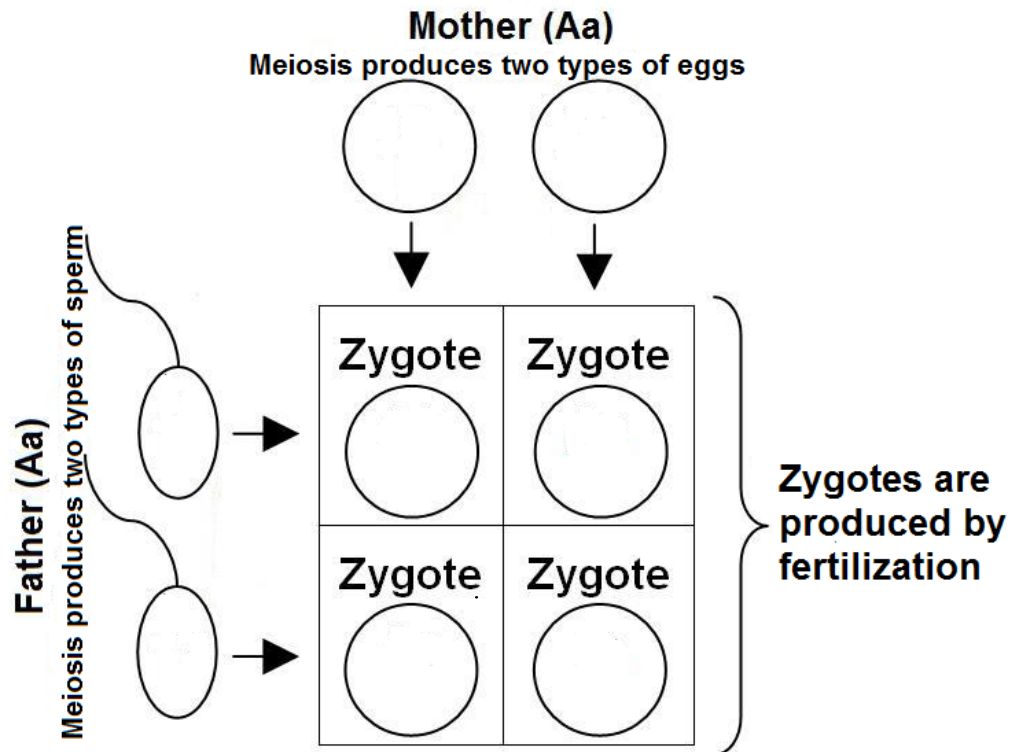

2. Next, model fertilization, using the model chromosome for each type of sperm to fertilize each type of egg. Write the genetic makeup of the resulting zygotes in the chart.

To answer the following questions, remember that each zygote undergoes repeated mitosis to become a child, so the child will have the same genetic makeup as the zygote.

3. What fraction of this couple's children would you expect to be **AA**? _____
4. What fraction of this couple's children would you expect to be **Aa**? _____
5. What fraction of this couple's children would you expect to be **aa**? _____

The children who have **AA** alleles will have normal pigmentation, and the children who have **aa** alleles will have albinism. These children are homozygous for the **A** allele or the **a** allele.

Homozygous means that both copies of the gene have the same allele.

The next question is: Will children who have **Aa** alleles have normal pigmentation or be albino? This type of combination of two different alleles is called **heterozygous**. Often, one allele in a heterozygous pair of alleles is **dominant** and the other allele is **recessive**; this means that the dominant allele determines the observable characteristic of the heterozygous individual. Typically, the dominant allele is symbolized by a capital letter, in this case **A** for the allele for normal pigmentation. Thus, heterozygous (**Aa**) individuals will have normal pigmentation.

6. What fraction of this couple's children would you expect to have normal pigmentation? _____
7. What fraction of this couple's children would you expect to have albinism? _____

The **genotype** refers to the genetic makeup of an individual. The **phenotype** refers to the observable physical and physiological characteristics of an individual.

8. Give an example of two individuals who have the same phenotype, but different genotypes for the albinism gene. Explain how two individuals with the same phenotype can have different genotypes.

Biologists frequently express the fractions of different genotypes or phenotypes as ratios. For example, for the mating between two heterozygous parents, the genotype fractions are $1/4$ **AA**, $2/4$ **Aa**, $1/4$ **aa**, which can also be expressed as a 1:2:1 ratio.

9. For the corresponding phenotypes, the fraction with normal pigmentation is _____ and the fraction with albinism is _____, so the corresponding ratio is _____.

Notice that the chart you completed on page 2 has been very useful in helping you to answer important questions about the inheritance of albinism. Biologists frequently use a simplified version of this chart, called a **Punnett Square**, to analyze inheritance. The chart below shows a Punnett Square for the example you have been analyzing.

	A	a
A	AA	Aa
a	Aa	aa

10. For this Punnett Square, use arrows to indicate the genetic makeup of each sperm and egg and circle the genetic makeup of each type of zygote.

11. Sally and Harry fall in love. They introduce Sally's identical twin, Emily, to Harry's identical twin, Ken. Soon there is a double wedding where Sally marries Harry and Emily marries Ken. Both Sally and Emily get pregnant. They wonder "Will their babies look exactly alike?" Answer their question, and explain your reasoning. (To answer this question, think about the children that could be produced if both pairs of identical twins are heterozygous **Aa**.)

Coin Toss Genetics

The way genes behave can easily be simulated using two-sided coins, where tails represent the recessive allele that controls pigment production (**a**), and heads represent the dominant allele (**A**). Suppose a parent is heterozygous (**Aa**). Then, tossing a coin and checking for tails up vs. heads up represents the 50-50 chance that an egg or sperm produced by the parent will include an **a** allele or an **A** allele. To simulate a mating between two heterozygous (**Aa**) parents, two students will each toss a coin and the result of the pair of coin tosses will indicate the pair of alleles contributed by an egg and a sperm to the baby that results from that mating.

Find someone to “mate” with.

1. Each of you will toss your coin, and this pair of coin tosses will indicate the pair of alleles in the first child produced by a mating of two heterozygous (**Aa**) parents. Make three more pairs of coin tosses to determine the genetic makeup for the second, third and fourth children in this family. Record how many of these 4 children had each of the 3 possible combinations (**AA**, **Aa**, or **aa**) in the row labeled "first family of 4 children" in the table below.
2. Now make 4 more pairs of coin tosses to indicate the alleles in a second family of 4 children. Record these genotypes in the second row in the table below.
3. Do this two more times and record the results in the third and fourth rows of the table below.

Genetic makeup of "children" produced by two heterozygous (**Aa**) parents

	AA	Aa	aa
First family of 4 children			
Next family of 4 children			
Next family of 4 children			
Next family of 4 children			
Total			
Predictions based on Punnett Square (page 3)	1/4 = 25%	2/4 = 50%	1/4 = 25%
Class data -- Percents (Total # children = _____)			

4. Add up your results to determine the total number of children from your coin tosses who had **AA**, **Aa**, and **aa**. Add your numbers to the table of class data.
6. For each family of 4 children produced by your coin toss matings, compare the results with the predictions from the Punnett Square. Are the numbers of **AA**, **Aa**, and **aa** genotypes in your families of 4 children similar to the predicted?

Did you get different results in different families?

Did any family have no albino (**aa**) children?

Did any family have 2 or more albino children?

7. Enter the results for the class data in the table on page 4. Are the percents of each genotype in the class data similar to the predictions of the Punnett Square?

If there is a difference between the results for the class data and the predictions, is this difference relatively small or large?

In many cases, the results for a family of four children will not match the predictions of the Punnett Square. Random variation in which particular sperm fertilizes which particular egg explains why the children in the individual families may differ considerably from the predictions based on the Punnett Square. The random variation observed in small samples usually averages out in large samples. Therefore, the results for a large number of children from multiple pairs of parents with the same genetic makeup are usually close to the predictions of the Punnett Square.

Genetics of Sex Determination

As you probably know, human males have an X and a Y chromosome (**XY**), whereas females have two X chromosomes (**XX**). A zygote must have at least one **X** chromosome to survive. The gene that causes the development of male anatomy is located on the Y chromosome. This gene is called **SRY**, which stands for sex-determining region of the Y chromosome. If a zygote has a Y chromosome with the SRY gene, the embryo will develop testes and male anatomy. If a zygote does not have a Y chromosome with the SRY gene, the embryo will develop ovaries and female anatomy.

Your understanding of meiosis and fertilization provides the basis for understanding the inheritance of X and Y chromosomes. During meiosis in a female, the two X-chromosomes separate, so each egg has a single X-chromosome. In males, even though the X and the Y-chromosomes are very different, they can nevertheless pair with each other and separate from each other during meiosis. This means that males produce two kinds of sperm; half have an X chromosome and half have a Y chromosome.

1. What will be the sex of a child produced when an egg is fertilized by a sperm that has a Y chromosome?

What type of sperm must fertilize an egg to result in a female child?

2. Draw a Punnett Square which shows the inheritance of the sex chromosomes. Use X to indicate an egg or sperm with an X chromosome and Y to indicate a sperm with a Y chromosome.

3. Based on this Punnett Square, what percent of children would you expect to be male?

4. To test this prediction, begin by writing down the initials of all the children your mother has had. Arrange these initials in order from the oldest to the youngest, indicating whether each was male or female.

5. Complete the following table.

	Total number of children	Number of males	% males
Your mother's children			
Children of the mothers of all the students in your class			
Predicted percent from Punnett square, page 5			

6. Next, compare the predicted percent male with the observed percent male for your mother's children, for the children of the mothers of the other members of your group, and for all the children in the class sample. How similar to the prediction are the observed results for individual families and for all the families combined?

Notice that the percent male children varies in different families and the percent male children in some families is very different from the predicted. To understand why, remember that each time a sperm fertilizes an egg to form a new zygote, there is random variation in whether the sperm has an X or Y chromosome. Random variation tends to average out in large samples, so the overall percent male children for all the mothers will usually be fairly close to the predicted 1/2.

7. To answer the following questions, look at your group's lists in question 4 above.

If a mother's first child is a son, is the next child necessarily a daughter?

If a mother's first child is a daughter, is the next child necessarily a son?

If a mother's first two children are sons, is the next child necessarily a daughter?

If a mother's first two children are daughters, is the next child necessarily a son?

These observations illustrate that you cannot predict the sex of the next child based on the sex of a previous child or children. Each time a sperm fertilizes an egg, the results are independent of any previous fertilizations that resulted in older brothers or sisters.

Genetics of Sickle Cell Anemia

Some alleles of certain genes can cause disease. An example is the gene for hemoglobin, the protein that carries oxygen in red blood cells. One allele codes for normal hemoglobin, while another allele codes for altered hemoglobin, called sickle cell hemoglobin. When a person is homozygous for the sickle cell allele, this causes a serious disease called sickle cell anemia. The sickle cell hemoglobin tends to clump into long rods that cause the red blood cells to assume a sickle shape, in contrast to the normal disk-shaped red blood cell shown on the left in the figure below.

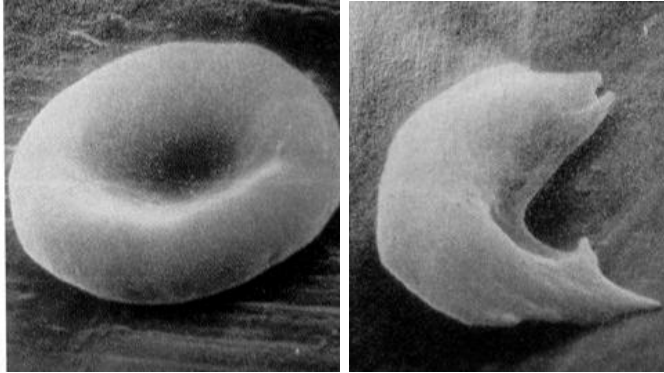

1. What problems might be caused by the sickle-shaped red blood cells?

A person who is heterozygous for the sickle cell and normal hemoglobin alleles usually does not have symptoms of sickle cell anemia, so in this respect they are like a person who is homozygous for the normal hemoglobin allele. This is why textbooks usually describe the sickle cell allele as recessive. However, people who are heterozygous for the sickle cell allele are not exactly like people who are homozygous for the normal hemoglobin allele.

People who are heterozygous for the sickle cell allele are less likely to develop severe malaria, an infection of the red blood cells which is transmitted by mosquitoes in many tropical countries. Thus, in areas where malaria is widespread, people who are heterozygous for the sickle cell allele are less likely to become seriously ill and die. Because of this advantage, the sickle cell allele became relatively common in regions like West Africa where malaria is common. Since African-Americans are descended from populations in which the sickle cell allele was relatively common, African-Americans have relatively high rates of the sickle cell allele (approximately 8% are heterozygous for this allele and 0.16% are homozygous).

2. Suppose that a person who is heterozygous for the sickle cell allele (**Ss**) marries a person who is also heterozygous for this allele (**Ss**). Draw a Punnett Square to show the expected genetic makeup of their children.

3. On average, what fraction of their children will suffer from sickle cell anemia?

4. On average, what fraction of their children will be heterozygous for the sickle cell allele? (These children will not have sickle cell anemia and will be less likely to develop severe malaria.)

Pedigree Analysis

Human geneticists illustrate the inheritance of a gene within a family by using a pedigree chart. On such a chart, males are symbolized by a square (\square) and females are symbolized by a circle (\circ). People who are affected by a disease are symbolized by a dark square or circle.

The pedigree chart below shows inheritance of albinism. 1 and 2 represent a couple who had five children, including a son who is labeled 3 and a daughter who is labeled 5. Only one of the children, 5, was albino. The son who is labeled 3 and his wife who is labeled 4 had four children, including a son who is labeled 6.

1. In the pedigree below write the genotypes of the individuals who are labeled with numbers, using (**A**) to represent the dominant allele and (**a**) to represent the recessive allele. Start by indicating the genotypes of 5 and 6. Next, draw a Punnett Square for parents 3 and 4 and their offspring to figure out what the genotypes for 3 and 4 must be.

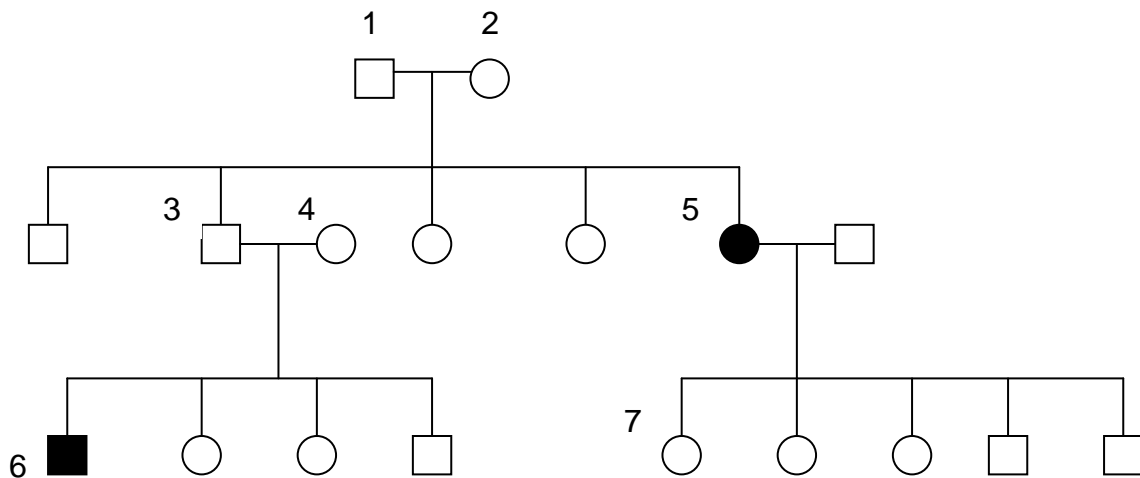

Next, determine the genotypes of 1 and 2. Finally, determine the genotype of 7.

Many other genes have a recessive allele which is inherited in the same manner as the recessive allele for albinism. These include the recessive alleles that cause some genetic diseases, such as sickle cell anemia, cystic fibrosis (a genetic disease that results in difficulty in breathing and serious illness), and phenylketonuria (a genetic disease that results in mental retardation unless detected at birth and treated with a special diet, etc.).

Challenge Question

Shown below is a pedigree chart for the inheritance of achondroplasia (ay-kon-druh-**play**-zhuh), a form of dwarfism. Dark circles or squares indicate individuals with achondroplasia. Examine the pedigree chart, and answer the following questions.

1. Is the allele that causes this form of dwarfism recessive or dominant?

How do you know?

2. Using **D** to represent the dominant allele and **d** to represent the recessive allele, write the genotypes of the indicated individuals. Start by indicating the genotypes of 2, 3 and 7. Next, draw a Punnett Square for parents 5 and 6 and their offspring to figure out what the genotypes for 5 and 6 must be.

Next, determine the genotypes of 1 and 4.

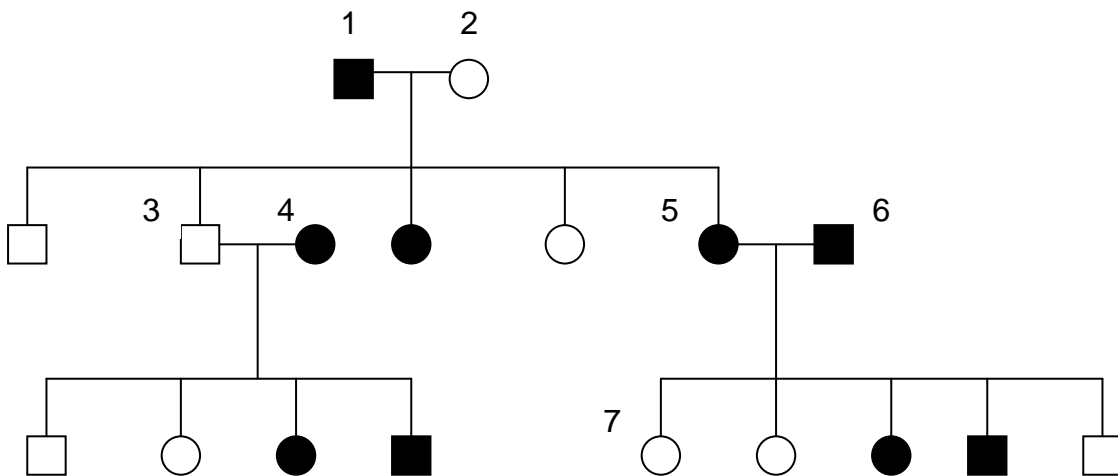

3. Based on the frequency of dwarfs among the people you have seen in your lifetime, do you think that the allele for achondroplasia is common or rare in the population?